

# Chemistry in Super Acids. II.<sup>1a</sup> Nuclear Magnetic Resonance and Laser Raman Spectroscopic Study of the Antimony Pentafluoride–Fluorosulfuric Acid (Sulfur Dioxide) Solvent System (“Magic Acid”). The Effect of Added Halides, Water, Alcohols, and Carboxylic Acids. Study of the Hydronium Ion

Auguste Commeyras<sup>1b,c</sup> and George A. Olah

Contribution from the Department of Chemistry, Case Western Reserve University, Cleveland, Ohio 44106. Received October 24, 1968

**Abstract:** Proton, <sup>19</sup>F nmr, and Raman spectroscopic studies on solutions of SbF<sub>5</sub>–HSO<sub>3</sub>F show the existence of equilibria 1–6. When SO<sub>2</sub> is used as a solvent the acidity of the system decreases. The equimolecular complex SbF<sub>5</sub>–SO<sub>2</sub> is formed shifting the equilibria 5 and 6 and consequently 4 to the left. Equilibrium 3 is shifted to the right. In all cases equilibrium 3 shifts to the right when the acidity of the system decreases and to the left when the acidity increases. When any base is protonated, the anion [Sb<sub>2</sub>F<sub>10</sub>SO<sub>3</sub>F]<sup>–</sup> is formed. Upon dehydration of alcohols or carboxylic acid, to form R<sup>+</sup> or RCO<sup>+</sup>, the water formed is immediately quenched (protonated) by excess acid to form [H<sub>3</sub>O]<sup>+</sup> which is in equilibrium with [H<sub>2</sub>OHOH<sub>2</sub>]<sup>+</sup>. On formation of the cations from haloorganic precursors (RX, RCOX), the anions [Sb<sub>2</sub>F<sub>11</sub>]<sup>–</sup> and [SbF<sub>6</sub>]<sup>–</sup> are in equilibrium.

In recent years the fluorosulfuric acid–antimony pentafluoride and the fluorosulfuric acid–antimony pentafluoride–sulfur dioxide systems have attained substantial importance as solvent media for generating stable carbonium ions and related cations. The high acidity and low nucleophilicity of the systems make them exceptionally suitable for stabilizing carbonium ions (“magic acid”).<sup>2</sup> The purpose of the present work is a detailed study of the HSO<sub>3</sub>F–SbF<sub>5</sub> and HSO<sub>3</sub>F–SbF<sub>5</sub>–SO<sub>2</sub> solvent systems. Woolf<sup>3a</sup> has reported that antimony pentafluoride gives conducting solutions in fluorosulfuric acid, indicating that SbF<sub>5</sub> behaves as an acid. However, no attempts were made to determine either the mode or degree of ionization. Gillespie, *et al.*,<sup>3b</sup> utilized conductometric, cryoscopic, and nuclear magnetic resonance techniques to study solutions of SbF<sub>5</sub> in fluorosulfuric acid. The results indicated the presence of H[SO<sub>3</sub>F–SbF<sub>5</sub>] and H[SO<sub>3</sub>F–(SbF<sub>5</sub>)<sub>2</sub>] species. Yet the scope of this study was limited since only solutions of less than 20 mol % antimony pentafluoride were investigated. We have shown that solutions of higher SbF<sub>5</sub> concentration including particularly the 1:1 molar system are most

(1) (a) Part I: G. A. Olah and R. H. Schlosberg, *J. Amer. Chem. Soc.*, **90**, 2726 (1968); (b) NATO Postdoctoral Research Investigator 1967–1968; (c) Faculté des Sciences, Université de Montpellier, France.

(2) (a) For a summary see, G. A. Olah, *Chem. Eng. News*, **45**, 76 (March 27, 1967). (b) We have no particular intention to proliferate the chemical literature with trivial names. The name “magic acid” has been used now for some years by research students in the senior author’s laboratories as a spontaneous laboratory abbreviation for concentrated solutions of SbF<sub>5</sub> in FSO<sub>3</sub>H, particularly the 1:1 molar system. It was cited in print first by others (for example: E. M. Arnett and J. W. Larsen, *Chem. Eng. News*, **46**, 36 (Feb 26, 1967)) and found its way into our publications rather reluctantly and infrequently since. There is, however, some justification for a brief trivial name for this rather remarkable, if not unique, acid system. It is one of the strongest acid systems known, allowing some very unusual chemistry (hence the reference to “magic”). We certainly agree with Gillespie’s general naming of the whole class of known very high acidity systems as super acids (R. J. Gillespie, *Accounts Chem. Res.*, **1**, 202 (1968)) and would like to avoid to make a capital case of trivial naming of compounds (R. J. Gillespie, K. Ouchi, and G. P. Pez, *Inorg. Chem.*, **8**, 63 (1969)). It should be emphasized, however, as also pointed out by Gillespie that acids like fluorosulfuric acid itself do not qualify as super acids.

(3) (a) A. A. Woolf, *J. Chem. Soc.*, 433 (1955); (b) R. C. Thompson, J. Barr, R. J. Gillespie, J. B. Milne, and B. A. Rothenbury, *Inorg. Chem.*, **4**, 1641 (1965).

important as solvents for the generation of carbonium ions. Thus a study of the whole range of SbF<sub>5</sub>–HSO<sub>3</sub>F concentrations is desirable.

This is especially true since the spectroscopic study of carbonium ions and particularly that of the vibrational Raman spectra required knowledge of the structure and the vibrational frequencies of the acid solvent system and the conjugate bases of the cations. Such a study would permit the unambiguous assignment of the characteristic Raman lines of the cations themselves.

## Results and Discussion

**A. Nmr Study of SbF<sub>5</sub>–HSO<sub>3</sub>F and SbF<sub>5</sub>–HSO<sub>3</sub>F–SO<sub>2</sub> Solutions.** **a. Study of SbF<sub>5</sub>–HSO<sub>3</sub>F Solutions.** In order to explain why SbF<sub>5</sub> behaves as an acid in solutions of SbF<sub>5</sub>–HSO<sub>3</sub>F with molecular ratio SbF<sub>5</sub>:HSO<sub>3</sub>F lower than 0.2, Gillespie, *et al.*,<sup>3b</sup> proposed equilibria 1–3. The existence of species I and II was

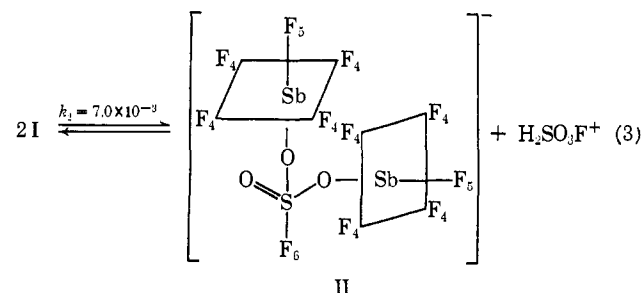
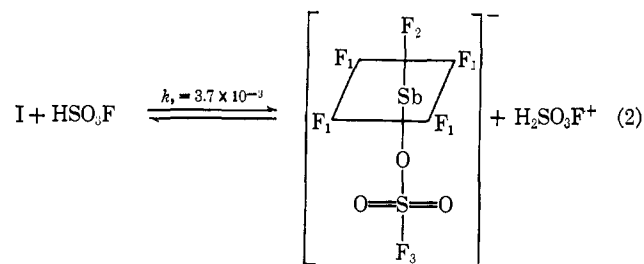
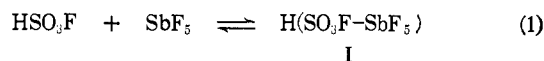

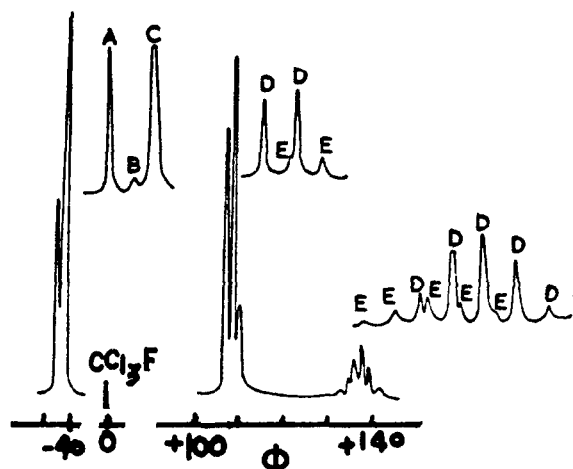

Figure 1.  $^{19}\text{F}$  nmr spectrum of a  $\text{SbF}_5\text{-HSO}_3\text{F}$  solution with a molecular ratio  $\text{SbF}_5\text{:HSO}_3\text{F} = 0.17$  at  $-67^\circ$ , according to Gillespie, *et al.*<sup>3b</sup>

I and II are in the ratio 80% to 20%, the nmr intensities are explained. The problem remaining is to show which of the species is I or II and thus permit their detection in more complex solutions.

The  $^{19}\text{F}$  nmr investigation of  $\text{SbF}_5\text{-HSO}_3\text{F}$  solutions with the molecular ratio of  $\text{SbF}_5\text{:HSO}_3\text{F}$  ranging between 0 and 1.4 was carried out. The spectra of solutions with molecular ratios between 0 and 0.4 are identical with respect to position and number of lines with those obtained by Gillespie, *et al.*<sup>3b</sup> In addition, the  $^{19}\text{F}$  spectrum of the  $\text{SbF}_5\text{:SO}_3\text{F} = 0.208$  solution indicates that I is the species present in the higher concentration. In the S- $^{19}\text{F}$  resonance region, the integrated ratio of peaks C to A + B shows that 0.171 mol of  $\text{HSO}_3\text{F}$  is bonded to  $\text{SbF}_5$  to form species I and II with a 6:1 ratio, respectively. Two explanations are possible: (1) 0.171:7 = 0.0244 mol of  $\text{HSO}_3\text{F}$  is bonded with  $\text{SbF}_5$  to form species I while the remaining 0.1464 mol is bonded with 2 mol of  $\text{SbF}_5$  to form species II; (2)

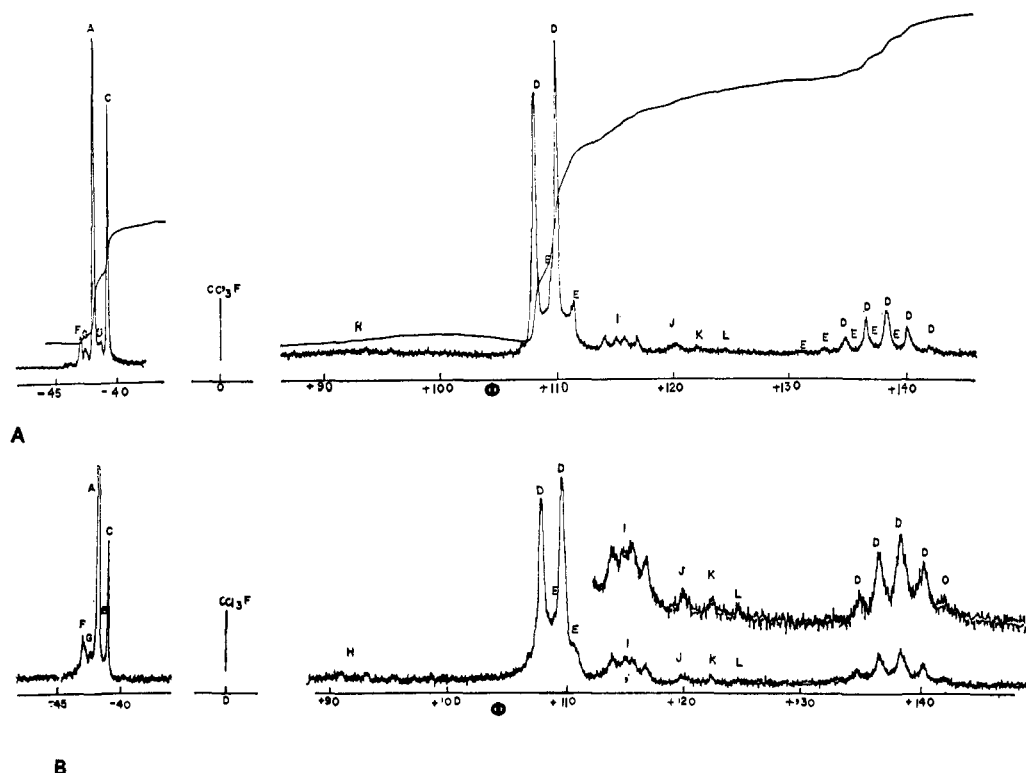

Figure 2.  $^{19}\text{F}$  nmr spectra of  $\text{SbF}_5\text{-HSO}_3\text{F}$  solutions with a molecular ratio: (A)  $\text{SbF}_5\text{:HSO}_3\text{F} = 0.799$  at  $-50^\circ$ ; (B)  $\text{SbF}_5\text{:HSO}_3\text{F} = 0.995$  at  $-50^\circ$ .

supported in the work of Gillespie by the  $^{19}\text{F}$  nmr spectrum of a solution with a molecular ratio  $\text{SbF}_5\text{:HSO}_3\text{F} = 0.17$  (Figure 1 reproduces Gillespie's spectrum). The species I is characterized by the peaks D constituting an  $\text{AX}_4$  spectrum with a chemical-shift difference measured from the center of the doublet to the center of the quintet of 1662 Hz and a coupling constant  $J_{\text{F}_1, \text{F}_2}$  of 100 Hz. The  $\text{F}_3$  fluorine bonded to sulfur is assigned the low-field peak A. Species II is characterized by the peaks E constituting an  $\text{AX}_4$  spectrum with a chemical-shift difference of 1415 Hz and  $J_{\text{F}_4, \text{F}_5} = 100$  Hz. The  $\text{F}_6$  fluorine bonded to sulfur yields the low-field peak B, C being the solvent peak.

The interpretation of these spectra in terms of species I and II seems reasonable and if the concentrations of

0.171:7 = 0.0244 mol of  $\text{HSO}_3\text{F}$  is bonded with 2 mol of  $\text{SbF}_5$  to form species II while the remaining 0.1464 mol is bonded to 1 mol of  $\text{SbF}_5$  to form species I. The calculated numbers of moles of  $\text{SbF}_5$  corresponding to each possibility indicate that 0.317 mol of  $\text{SbF}_5$  is required for arrangement 1 and 0.195 mol for 2. Since the mixture was formed from a solution containing 0.208 mol of  $\text{SbF}_5$  and 1 mol of  $\text{HSO}_3\text{F}$  only the second possibility is in agreement with the hypothesis of Gillespie, *et al.*<sup>3b</sup> The proposed structure of I and II will be confirmed in section C-a. In the  $^{19}\text{F}$  nmr spectrum of the  $\text{SbF}_5\text{-HSO}_3\text{F}$  solutions with mole ratios between 0.4 and 1.4 in addition to the previous resonances (A-E), the simultaneous appearance of new signals (Figure 2) the intensities of which increase with

**Table I.** Composition of  $\text{SbF}_5\text{-HSO}_3\text{F}$  solutions

	$\text{H}[\text{SbF}_5\text{-SO}_2\text{F}]$	$\text{H}[\text{Sb}_2\text{F}_{10}\text{SO}_3\text{F}]$	$\text{H}[\text{Sb}_2\text{F}_{11}]$	$\text{HSbF}_6$	$\text{HS}_2\text{O}_6\text{F} + \text{HS}_3\text{O}_9\text{F}$	$\text{HSO}_3\text{F}$
$\text{SbF}_5\text{-HSO}_3\text{F} = 0.5$	0.37	0.05	0.01	0.005	0.015	0.55
$\text{SbF}_5\text{-HSO}_3\text{F} = 0.8$	0.62	0.05	0.03	0.01	0.04	0.29

increasing concentration of  $\text{SbF}_5$  are observed. At the higher concentrations of  $\text{SbF}_5\text{-HSO}_3\text{F}$  the resolution of the nmr signals progressively decreases because of the increasing viscosity of the system (Figure 2B). A typical spectrum displays (Figure 2B) two new lines F-G in the  $\text{S-}^{19}\text{F}$  region and a very weak absorption H centered on  $\phi$  93 in the  $\text{S-}^{19}\text{F}$  region, four signals I centered on  $\phi$  115.3, and three very weak signals J, K, and L at  $\phi$  120, 122, and 124. Signal L is obtained only in the spectrum of the equimolecular solutions (Figure 2B). The signals K and L have not been interpreted. The other signals were interpreted by considering species

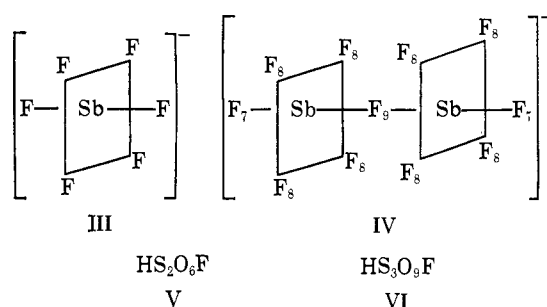

III-VI. The existence of species III and IV was recently proposed for  $\text{HF-SbF}_5$  solutions by Gillespie and Moss<sup>4</sup> on the basis of  $^{19}\text{F}$  nmr spectra of these solutions. Three resonances with the relative areas 1:8:2 respectively were assigned to  $\text{F}_9$ ,  $\text{F}_8$ ,  $\text{F}_7$  (species IV).  $\text{F}_9$  is observed as a five-line pattern with a coupling constant  $J_{\text{F}_9, \text{F}_8} = 53$  Hz. It is presumed to be coupled equally to the set of eight equivalent fluorines  $\text{F}_8$  and should display a nine-line pattern of relative areas 1:7:28:56:70:56:28:7:1, of which only the five most intense lines would be observed. The signal  $\text{F}_8$  is split into four lines of approximately equal intensity by spin-spin coupling with  $\text{F}_9$  ( $J_{\text{F}_8, \text{F}_9} = 53$  Hz) and with  $\text{F}_7$  ( $J_{\text{F}_8, \text{F}_7} = 100$  Hz).  $\text{F}_7$  is a quintet ( $J_{\text{F}_7, \text{F}_8} = 100$  Hz). A single broad peak 320 Hz upfield from the center of  $\text{F}_8$  was attributed to the six equivalent fluorines of species III. In the spectra of  $\text{SbF}_5\text{-HSO}_3\text{F}$  solutions we have assigned the very weak unresolved resonance H centered on  $\phi$  93 to  $\text{F}_9$  of the species IV. This signal resolved in the spectra 4, 7, 8, and 9 is actually a multiplet with a coupling constant of 55 Hz. The four-line signal I is assigned to  $\text{F}_8$  of the species IV. It appears as a doublet  $J = 100$  Hz of doublets  $J = 55$  Hz. The quintet characterizing the two  $\text{F}_7$  fluorine atoms is overlapped by the quintets of species I and II.

Signal J is assigned to species III. In order to confirm the existence of the type IV structure it was necessary to perform a decoupling experiment. The center of the multiplet H was irradiated and the signal I assigned to the eight  $\text{F}_8$  fluorine atoms was effectively decoupled to give a doublet ( $J = 100$  Hz) while the signal assigned to structure III was not altered (Figure 7). In the  $\text{S-}^{19}\text{F}$  region the signals F and G are assigned to the species V ( $\text{HS}_2\text{O}_6\text{F}$ ) and VI ( $\text{HS}_3\text{O}_9\text{F}$ ).

(4) R. J. Gillespie and K. C. Moss, *J. Chem. Soc., A*, 1170 (1966).

The existence of these species in  $\text{SO}_2\text{-HSO}_3\text{F}$  solutions has been previously proposed on the basis of Raman and  $^{19}\text{F}$  nmr studies.<sup>5</sup>

In  $\text{SO}_2\text{-HSO}_3\text{F}$  solutions with high concentrations of antimony pentafluoride the formation of species III-VI can be understood by considering reactions 4-6. The

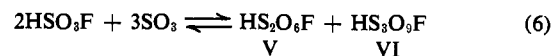
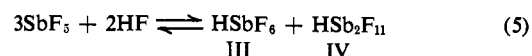

$\text{HF}$  arising from the autodissociation equilibrium (4) is complexed by  $\text{SbF}_5$  to form species III and IV. The sulfur trioxide released in this reaction reacts with excess fluorosulfuric acid to give the mixed anhydrides V and VI. By integration of the  $^{19}\text{F}$  nmr spectra we have determined (Table I) the constitution, in moles, of the  $\text{SbF}_5\text{-HSO}_3\text{F}$  solutions with molecular ratios 0.5 and 0.8. For a solution with an equimolecular ratio the concentration of free  $\text{HSO}_3\text{F}$  is still equal to 17% of the starting concentration (Figure 2B).

**b. Study of  $\text{SbF}_5\text{-HSO}_3\text{F-SO}_2$  Solutions.** The structures of  $\text{SbF}_5\text{-HSO}_3\text{F}$  solutions with molecular ratios lower than 0.4 are practically unchanged by the addition of sulfur dioxide as shown by their  $^{19}\text{F}$  spectra. But those solutions with molecular ratio higher than 0.4 were clearly modified in the same solvent. For example, the  $^{19}\text{F}$  nmr spectra of solutions with a molecular ratio  $\text{SbF}_5\text{:HSO}_3\text{F} = 0.8$  to 1.0 in sulfur dioxide solvent (Figure 3) show an important difference when compared with those recorded for the same solutions without sulfur dioxide (Figure 2). The characteristic peaks of species III, IV, V, and VI disappear and the formation of a doublet M ( $J = 100$  Hz) centered at  $\phi$  105.67 is noted. The intensity of this doublet is considerably greater than that of any other species in the equimolecular solution (Figure 3B). We assign this doublet to the four equivalent fluorines in the equimolecular complex  $\text{SbF}_5\text{-SO}_2$ .

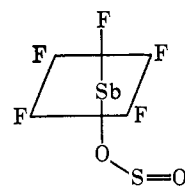

The structure of this complex (mp 57°) was recently determined by X-ray spectroscopy.<sup>6</sup> The authors of this work noted that the  $^{19}\text{F}$  nmr spectrum of the complex in sulfur dioxide solvent consisted of a doublet ( $J = 100$  Hz) centered at  $\phi$  105.67 with intensity 4, and a broad unresolved absorption centered at  $\phi$  141.58 with intensity 1.

(5) R. J. Gillespie and E. A. Robinson, *Can. J. Chem.*, **40**, 675 (1962).

(6) J. W. Moore, H. W. Baird, and H. B. Miller, *J. Amer. Chem. Soc.*, **90**, 1358 (1968).

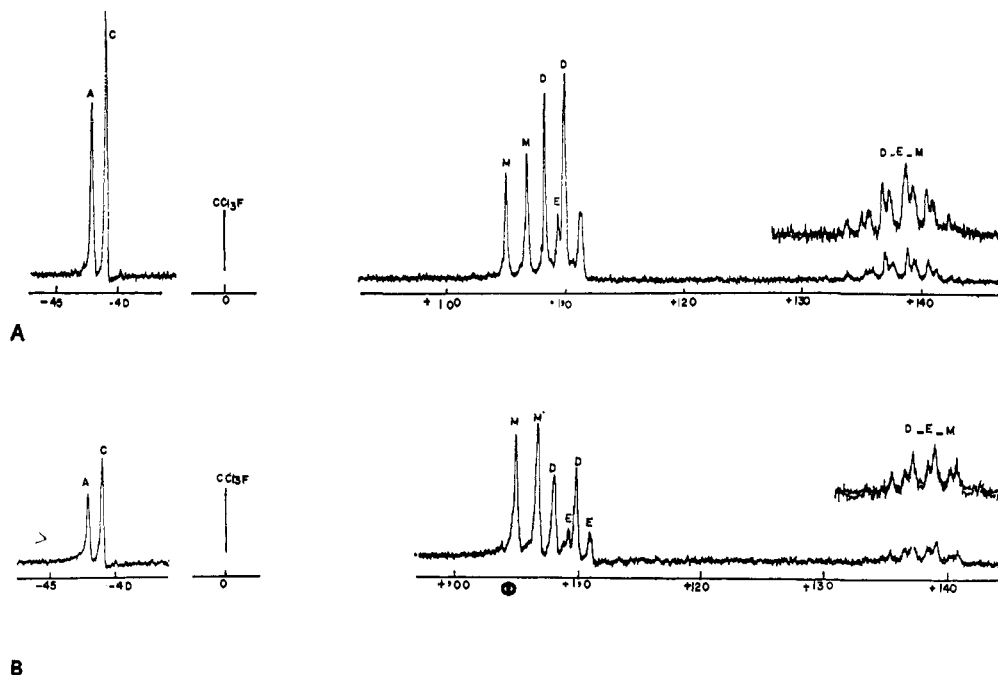

Figure 3.  $^{19}\text{F}$  nmr spectra of  $\text{SbF}_5\text{-HSO}_3\text{F-SO}_2$  solutions: (A)  $\text{SbF}_5$  (0.788 mol) +  $\text{HSO}_3\text{F}$  (1 mol) +  $\text{SO}_2$  (1.66 mol) at  $-80^\circ$ ; (B)  $\text{SbF}_5$  (0.995 mol) +  $\text{HSO}_3\text{F}$  (1 mol) +  $\text{SO}_2$  (5.98 mol) at  $-95^\circ$ .

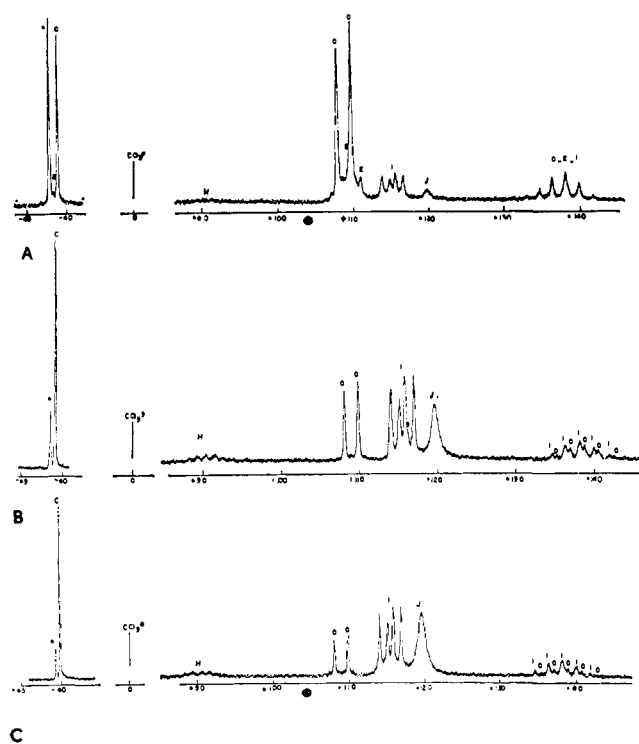

Figure 4.  $^{19}\text{F}$  nmr spectra of  $\text{SbF}_5\text{-HSO}_3\text{F-HF}$  solutions: (A)  $\text{SbF}_5$  (0.799 mol) +  $\text{HSO}_3\text{F}$  (1 mol) +  $\text{HF}$  (0.19 mol) at  $-50^\circ$ ; (B)  $\text{SbF}_5$  (0.799 mol) +  $\text{HSO}_3\text{F}$  (1 mol) +  $\text{HF}$  (0.534 mol) at  $-50^\circ$ ; (C)  $\text{SbF}_5$  (0.799 mol) +  $\text{HSO}_3\text{F}$  (1 mol) +  $\text{HF}$  (0.716 mol) at  $-50^\circ$ .

We studied the  $^{19}\text{F}$  nmr spectra of  $\text{SbF}_5$  solutions in sulfur dioxide solvent and obtained at  $-90^\circ$  an  $\text{AX}_4$  spectrum (a doublet  $J = 100$  Hz centered at  $\delta$  105.67 and a well-resolved quintet  $J = 100$  Hz centered on  $\delta$  141.58).

From a solution of  $\text{SbF}_5\text{:HSO}_3\text{F} > 0.4 + \text{SO}_2$  it was possible at low temperatures, depending on the con-

centration of  $\text{SO}_2$ , to obtain this complex as a crystalline solid compound. After removal by centrifugation, the  $^{19}\text{F}$  nmr spectrum of the solution shows a significant decrease in the intensity of the doublet, M, confirming our assignment. The formation of the  $\text{SbF}_5\text{SO}_2$  complex can obviously affect eq 4, 5, and 6. Competition of sulfur dioxide and HF for  $\text{SbF}_5$  can shift equilibria to the left accompanied by the regeneration of fluorosulfuric acid.

**B. Changes in the Structure of  $\text{SbF}_5\text{-HSO}_3\text{F}$  Solutions on Addition of Acetyl and *t*-Butyl Fluorides and Chlorides.** Acetyl and *t*-butyl halides in addition to hydrogen halides were used to study the effect of halide ions on the acid solutions because the carbonium ions generated,  $\text{CH}_3\text{CO}^+$  and  $(\text{CH}_3)_3\text{C}^+$ , are among the most well characterized.<sup>7,8</sup>

Of the several  $\text{SbF}_5\text{-HSO}_3\text{F}$  solutions studied we were particularly interested in those with molecular ratios between 0.7 and 1.0. These solutions were shown to contain all of the species previously identified permitting the investigation of the progressive changes in each species caused by the action of  $\text{HX}$ ,  $\text{CH}_3\text{COX}$ , or  $(\text{CH}_3)_3\text{CX}$  (where  $\text{X} = \text{F}, \text{Cl}$ ).

We followed these changes by comparing the  $^{19}\text{F}$  nmr spectra of solutions obtained before and after addition of the solutes. The spectra shown are those obtained from  $\text{SbF}_5\text{-HSO}_3\text{F}$  solutions of molecular ratio near 0.8. Because of their greater viscosity, spectra of solutions with higher molecular ratios are not as well resolved, but the observed changes are in all cases identical.

**a. Effect of HF and HCl.** To an  $\text{SbF}_5\text{-HSO}_3\text{F}$  solution with a molecular ratio 0.799 (Figure 2A) we added progressively 2.40 mol of HF. The first change observed (after addition of 0.19 mol of HF, Figure 4A)

(7) F. P. Boer, *J. Amer. Chem. Soc.*, **88**, 1572 (1966).

(8) G. A. Olah, E. B. Baker, J. C. Evans, W. S. Tolgyesi, J. S. McIntyre, and I. J. Bastien, *ibid.*, **86**, 1360 (1964).

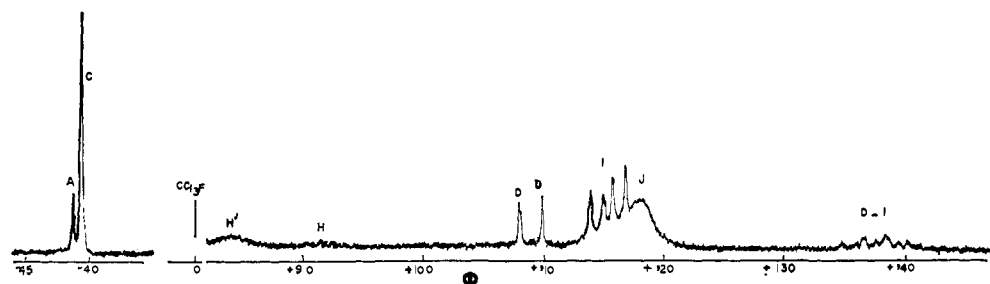

Figure 5.  $^{19}\text{F}$  nmr spectrum of  $\text{SbF}_5$  (0.799 mol) +  $\text{HSO}_3\text{F}$  (1 mol) +  $\text{HCl}$  (0.72 mol) at  $-50^\circ$ .

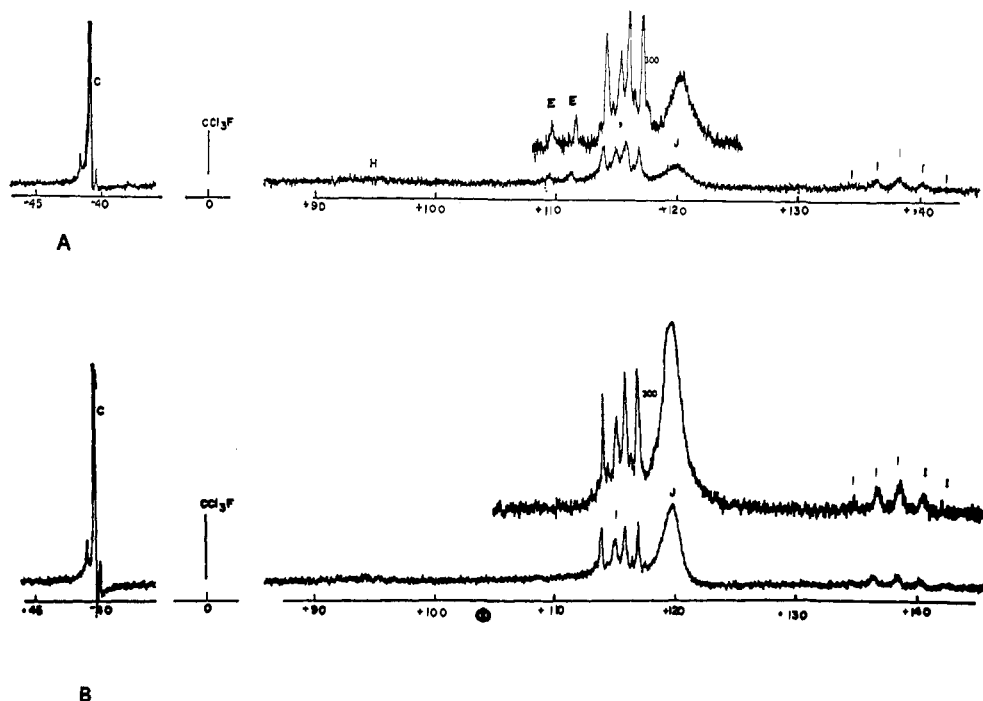
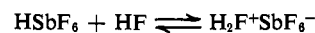

Figure 6.  $^{19}\text{F}$  nmr spectra of solutions: (A)  $\text{SbF}_5$  (0.790 mol) +  $\text{HSO}_3\text{F}$  (1 mol) +  $\text{SO}_2$  (4.24 mol) +  $(\text{CH}_3)_3\text{CF}$  (0.72 mol) at  $-90^\circ$ , (B)  $\text{SbF}_5$  (0.79 mol) +  $\text{HSO}_3\text{F}$  (1 mol) +  $\text{SO}_2$  (3.09 mol) +  $(\text{CH}_3)_3\text{CF}$  (0.790 mol) at  $-95^\circ$ .

was the disappearance of the characteristic peaks F and G of species V and VI and also the disappearance of the unidentified very weak signals K and L. In the same spectrum a small but appreciable increase in the intensity of characteristic peaks of species III and IV is observed. The disappearance of species V and VI can be understood by considering the reactions shown in eq 4 and 6. A fraction of added HF reacts with  $\text{SO}_3$  to regenerate fluorosulfuric acid. As for the increase in the intensity of the characteristic absorptions of the species III and IV, it is further increased by an addition of more HF (up to 0.534 mol, Figure 4B) at which point we note the disappearance of the characteristic peaks E and B of the species II. Upon further addition HF progressively reacts with species I (absorptions A and D) to form new quantities of IV ( $\text{HSb}_2\text{F}_{11}$ ), III ( $\text{HSbF}_6$ ), and VII ( $\text{HSO}_3\text{F}$ ). With a quantity of HF equal to 0.716 mol (89% molar compared with  $\text{SbF}_5$ ) only 10% of the  $\text{SbF}_5$  still is associated with  $\text{HSO}_3\text{F}$  in the complex I,  $\text{HSO}_3\text{F}-\text{SbF}_5$  (spectrum Figure 4C). It is necessary to add at least 2.4 mol of HF to eliminate quantitatively the last 10% of species I. No new signals were observed in the  $^{19}\text{F}$  nmr spectra of this solution but only a change in the intensity ratio of the characteristic peaks of the species  $\text{HSb}_2\text{F}_{11}$  and  $\text{HSbF}_6$  in favor of  $\text{HSbF}_6$ . This change is easily explained by the

reactions



In the spectral S- $^{19}\text{F}$  region we noticed only one peak characteristic of free fluorosulfuric acid. When HCl is substituted for HF we obtained analogous results but generally the spectra are not as well resolved (Figure 5). This effect is certainly due to fluorine-chlorine exchange leading to formation of products of type III and IV more or less chlorine substituted.

**b. Effect of  $(\text{CH}_3)_3\text{CF}$ ,  $(\text{CH}_3)_3\text{CCl}$ ,  $\text{CH}_3\text{COF}$ , and  $\text{CH}_3\text{COCl}$ .** The addition of *t*-butyl and acetyl halides to  $\text{SbF}_5$ - $\text{HSO}_3\text{F}$  solutions with molecular ratios higher than 0.7 leads to analogous modifications of the solvent structure. The previous remarks about chlorine compounds are also applicable in these cases.

The first of the changes observed, as with hydrogen halides, is the disappearance of V and VI (signals F and G). This result can be explained by the same argument described previously for hydrogen halides. The second change does not involve the disappearance of the signals E and B of II. What is observed however is the disappearance of signals D and A of species I while characteristic signal E of species II remains visible in the spectrum (Figure 6A). When  $(\text{CH}_3)_3\text{CF}$

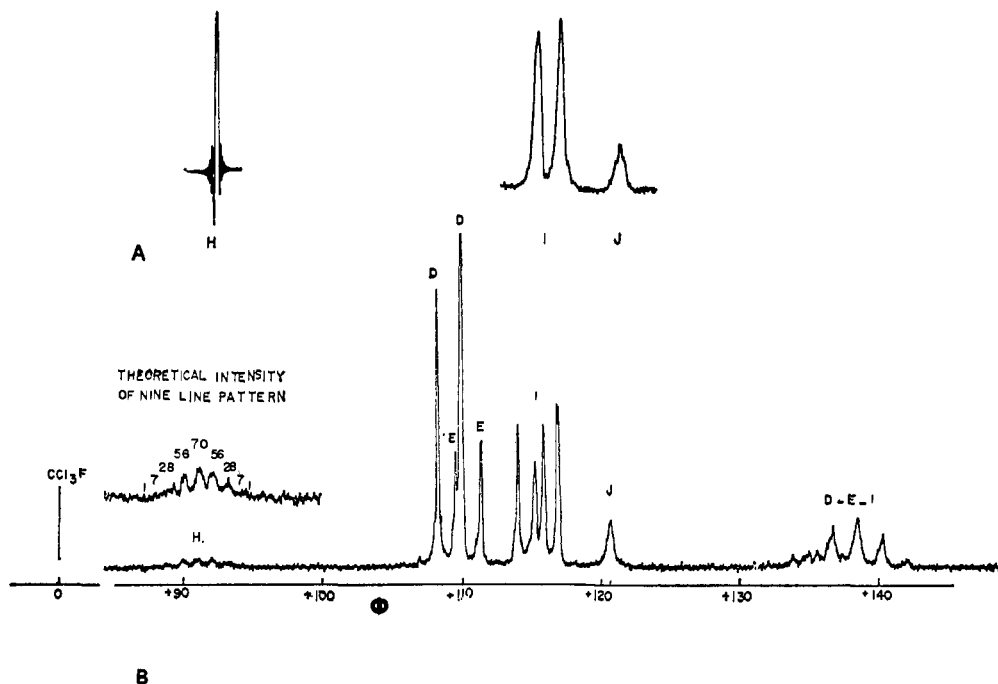

Figure 7.  $^{19}\text{F}$  nmr spectra of solution formed by  $\text{SbF}_5$  (0.785 mol),  $\text{HSO}_3\text{F}$  (1 mol), and  $\text{CH}_3\text{COF}$  (0.24 mol) at  $-60^\circ$ ; (A) four lines I and line J, after the irradiation of the multiplet H; (B) complete spectrum on the Sb-F region.

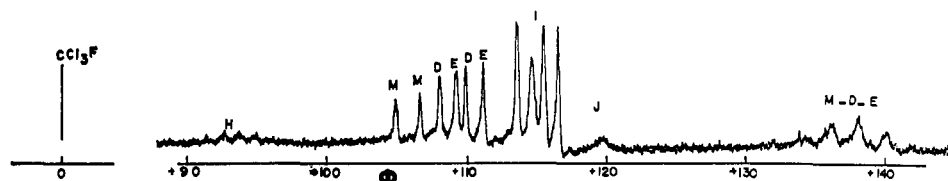

Figure 8.  $^{19}\text{F}$  nmr spectrum of a solution formed by  $\text{SbF}_5$  (0.8 mol),  $\text{HSO}_3\text{F}$  (1 mol),  $\text{SO}_2$  (3.50 mol), and  $(\text{CH}_3)_3\text{CF}$  (0.4 mol) at  $-95^\circ$ .

and  $\text{SbF}_5$  are present in equal concentration, the characteristic peaks of species I and II are completely eliminated from the spectrum (Figure 6B). The antimony pentafluoride is found quantitatively in the forms III and IV. In all cases studied we could verify by integration of the  $^{19}\text{F}$  nmr spectra of the solutions that we had (by raising the medium to an appropriate temperature) obtained complete ionization of halogenated organic compounds. The alkylcarbonium ion complexes obtained by Olah<sup>2</sup> upon ionization of alkyl fluorides (chlorides) in excess  $\text{SbF}_5$ , as well as in  $\text{SbF}_5\text{-SO}_2$  and  $\text{SbF}_5\text{-SO}_2\text{ClF}$  solutions, must be therefore considered as true carbonium ions which are present depending on conditions not necessarily as hexafluoroantimonates but with  $\text{Sb}_2\text{F}_{11}^-$  (or higher polymeric) anions. These findings will be



reported in detail in a later publication.

In the case of acetyl fluoride it was not possible to obtain solutions with  $\text{SbF}_5\text{-CH}_3\text{COF}$  of equimolecular concentrations because of precipitation of the ionic complex  $(\text{CH}_3\text{CO}^+\text{SbF}_6^-)$ . Figure 7A is the  $^{19}\text{F}$  nmr spectrum of a 30% solution. In this spectrum we note very clearly, centered at  $\delta$  91, the multiplet H assigned to  $\text{F}_\alpha$  of the species IV. The decoupling experiment previously mentioned was carried out on this spectrum confirming the structure of the species (Figure 7).

**c. Use of Sulfur Dioxide as Solvent.** To an  $\text{SbF}_5\text{-HSO}_3\text{F-SO}_2$  solution (Figure 3A) we added *t*-butyl fluoride in identical concentration with that of  $\text{SbF}_5$ . The  $^{19}\text{F}$  spectra of this solution (Figure 6B) show no trace of species I and II or the complex  $\text{SbF}_5\text{-SO}_2$ . All of the  $\text{SbF}_5$  can be found in species III and IV which are thus stable in the presence of sulfur dioxide. As previously mentioned, when HF was in competition with both Lewis acids  $\text{SbF}_5$  and  $\text{SO}_3$  the species III and IV were not stable, *e.g.*,  $\text{SbF}_6^-$  and  $\text{Sb}_2\text{F}_{11}^-$  are unstable in the presence of excess  $\text{SO}_3$ . However, that is not the case here since  $\text{SO}_3$  is not present. If the concentration of *t*-butyl fluoride is lower than that of  $\text{SbF}_5$ , species I, II, III, and IV are all present in solutions as shown in the  $^{19}\text{F}$  spectra, Figure 8. The existence of the characteristic signal M of the  $\text{SbF}_5\text{-SO}_2$  complex can also be seen for this system although the concentration is low. This complex certainly has the same order of stability as complexes I and II with regard to  $\text{F}^-$  derived from the ionization of  $(\text{CH}_3)_3\text{CF}$ . Analogous results were obtained when either HF or HCl was used (Figure 9). These observations and those discussed previously (section A-b) give a qualitative explanation of observations in our laboratory which suggest that the dilution of  $\text{SbF}_5\text{-HSO}_3\text{F}$  solutions by  $\text{SO}_2$  decreases the acidity of this system.

At this point it seems proper to comment on the use of  $\text{SbF}_5\text{-HSO}_3\text{F-SO}_2$  solutions as solvent for obtaining the vibrational spectra of organic cations. If the con-

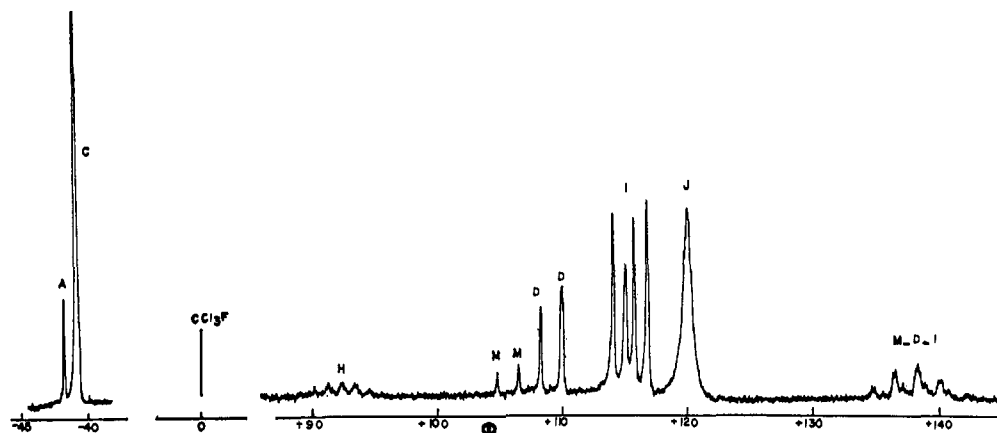
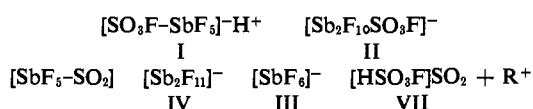

Figure 9.  $^{19}\text{F}$  nmr spectrum of solution formed by  $\text{SbF}_5$  (0.7 mol) +  $\text{HSO}_3\text{F}$  (1 mol),  $\text{SO}_2$  (0.86 mol), and  $\text{HF}$  (0.61 mol) at  $-70^\circ$ .

centration of the precursor haloorganic compounds is identical with that of  $\text{SbF}_5$ , the cations are ideally accompanied by only  $\text{Sb}_2\text{F}_{11}^-$ ,  $\text{SbF}_6^-$ ,  $\text{HSO}_3\text{F}$ , and  $\text{SO}_2$ . We can schematically represent these systems as:  $\text{Sb}_2\text{F}_{11}^-$ ,  $\text{SbF}_6^-$ ,  $\text{HSO}_3\text{F}$ ,  $\text{SO}_2 + \text{R}^+$ , or  $\text{RCO}^+$ . It is also clear that by using a hydrogen halide instead of a haloorganic compound we obtain solutions which differ from the previous ones only by substitution of  $\text{H}^+$  for  $\text{R}^+$ :  $\text{Sb}_2\text{F}_{11}^-$ ,  $\text{SbF}_6^-$ ,  $\text{HSO}_3\text{F}$ , and  $\text{SO}_2 + \text{H}^+$ .

Making the reasonable assumption that the solvated proton does not have a vibrational spectrum and that the vibrational frequencies of the gegenions are not affected by differences due to solvation of  $\text{H}^+$  and  $\text{R}^+$ , the characteristic frequencies of the organic cation could be obtained by the difference between the two vibrational spectra. In practice however, it is impossible due to solubilities and fluorescence to obtain Raman spectra of  $\text{RX-SbF}_5\text{-HSO}_3\text{F}$  solutions of the desired composition ( $\text{RX-SbF}_5$ , 1:1). Therefore the vibrational spectra of the cations are obtained always in the presence of anions I, II, and the  $\text{SbF}_5\text{-SO}_2$  complex which are present in the systems  $\text{RX}:\text{SbF}_5 < 1$ .



We have seen previously that in this case the solutions formed by adding  $\text{HF}$  or  $\text{HCl}$  to  $\text{SbF}_5\text{-HSO}_3\text{F-SO}_2$  mixtures were not absolutely identical with those formed from equivalent amounts of halogenated organic compounds since they do not contain species II.

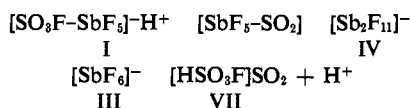

The answer to the problem is given in subsequent discussion of vibrational spectra where we first verify the respective concentrations of species I and II and then verify whether or not the vibrational spectrum of complex II displays different lines than those already observed.

The use of  $\text{SO}_2\text{ClF}$  and  $\text{SO}_2\text{F}_2$  as solvents for super acid systems was also introduced in our laboratories during recent years. They possess lower nucleophilicity than  $\text{SO}_2$ , which itself can react with certain carbonium ion systems causing sulfination.  $\text{SO}_2\text{ClF}$

particularly has good ionizing properties, and both compounds freeze only at low temperatures. A more detailed study of  $\text{FSO}_3\text{H}$ ,  $\text{SbF}_5$ ,  $\text{FSO}_3\text{H-SbF}_5$ , and related acid systems in  $\text{SO}_2\text{ClF}$  will be reported in a forthcoming paper.

**C. Changes of  $\text{SbF}_5\text{-HSO}_3\text{F}$  Solutions by  $\text{H}_2\text{O}$ ,  $\text{RCO}_2\text{H}$ , and  $\text{ROH}$ .** Although the protonation and ionization of carboxylic acids and alcohols were studied in super acid systems,<sup>9,10</sup> the form in which the water is found after elimination was never clearly established.

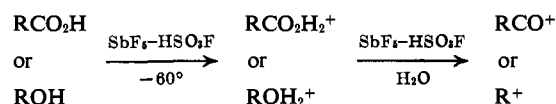

In the particular case of the  $\text{SbF}_5\text{-HSO}_3\text{F}$  system water can be associated in an intermediate complex of hydrolysis;<sup>10</sup> however, generally it is assumed that it is quenched as the protonated form  $[\text{H}_3\text{O}]^+$ .<sup>11</sup> In order to clarify this matter we studied  $\text{SbF}_5\text{-HSO}_3\text{F}$  solutions by following changes of structure as influenced by the action of water, carboxylic acids, or alcohols.

**a. Study of the  $\text{SbF}_5\text{-HSO}_3\text{F-H}_2\text{O}$  Solutions.** The pmr spectra of  $\text{SbF}_5\text{-HSO}_3\text{F}$  solutions show a single peak because the protons are in fast equilibrium between the previously discussed different species. When small amounts of water are added to these solutions a second pmr signal, the intensity of which increases with the concentration of water, appears. Thus we were able to monitor this addition by measuring the ratio of the intensity of the water peak and the acid peak,  $h_{\text{water}}/h_{\text{acid}}$  ( $h$  being the integrated area).

The position of these absorptions (from external TMS as reference) is a function of both the molecular ratio of  $\text{SbF}_5\text{-HSO}_3\text{F}$  and water concentration. Indeed, for a molecular ratio between 0.1 and 1.0 and a low concentration of water ( $h_{\text{water}}/h_{\text{acid}} = 0.01$ ) the peak due to the hydrogen acids varies from  $\delta$  11.0 to 12.8 while the peak due to the water shows little variation ( $\delta$  10.25). On the other hand, if the concentration of water is further increased the two peaks progressively approach each other and coalesce between  $\delta$  10.5 and 11.0.

(9) G. A. Olah, J. Sommer, and E. Namanworth, *J. Amer. Chem. Soc.*, **89**, 3576 (1967).

(10) G. A. Olah and A. M. White, *ibid.*, **89**, 3591 (1967), and references given therein.

(11) (a) M. Brookhart, G. C. Levy, and S. Winstein, *ibid.*, **89**, 1735 (1967).

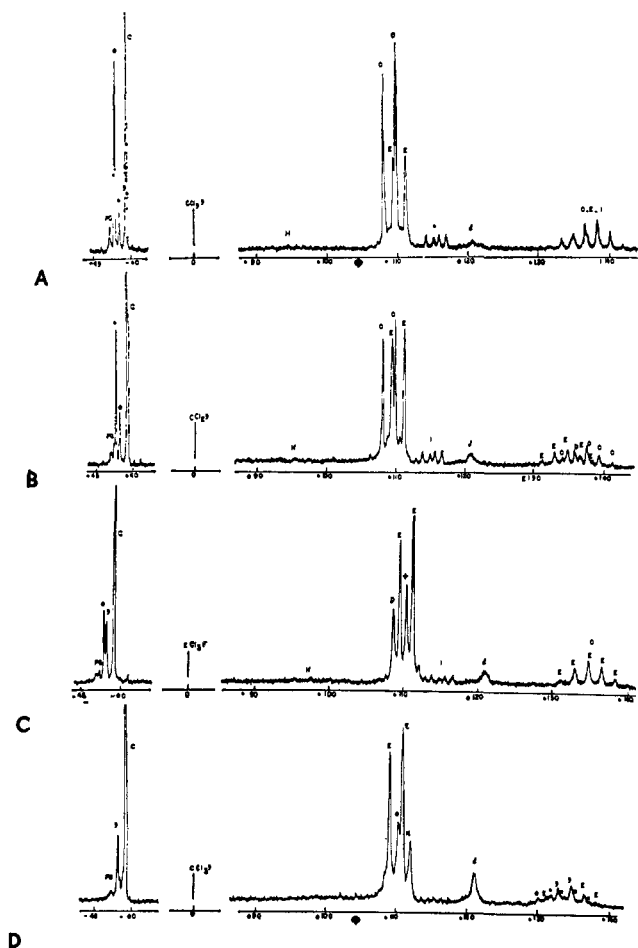
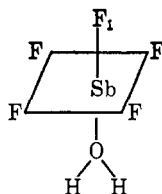

Figure 10.  $^{19}\text{F}$  nmr spectra of  $\text{SbF}_5:\text{HSO}_3\text{F} = 0.7$  solution with a ratio  $h_{\text{water}}/h_{\text{acid}}$  equal to: (A) 0.29, (B) 0.53, (C) 0.71, (D) 1.3.

We added water dropwise to an  $\text{SbF}_5\text{-HSO}_3\text{F} = 0.7$  solution until the water and acid peaks coalesced and followed the changes in the  $^{19}\text{F}$  nmr spectrum of solutions (Figure 10) with  $h_{\text{water}}/h_{\text{acid}} = 0.29, 0.53, 0.71,$  and  $1.3$ . We will see subsequently the relation between this ratio and the real water concentration present in the system.

It is clear from these spectra that after each addition of water the concentration of species II (signals E and B) increases and that of species I (signals D and A) decreases. When the ratio  $h_{\text{water}}/h_{\text{acid}}$  is near 0.9, the concentration of species I is negligible and the signal I, characteristic of species IV, disappears. In these spectra a doublet ( $J = 100$  Hz), the intensity of which increases with addition of water, is also observed. This doublet, N, is clearly visible in the spectrum of the solution with a ratio  $h_{\text{water}}/h_{\text{acid}}$  equal to 1.3 (Figure 10). Although we have not yet confirmed this assignment, signal N may be due to the four equivalent fluorine atoms of the equimolecular complex between antimony pentafluoride and water. The fifth fluorine



atom of this species, which is expected to appear as a quintet, is unobservable probably because of its weak intensity and overlapping with the quintet of species II.

The disappearance of signal I characteristic of species IV can be explained by the formation of  $\text{SbF}_5\text{-OH}_2$  complex. The signal, J, characteristic of  $\text{HSbF}_6$  seems

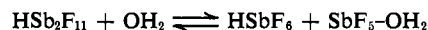

as a matter of fact increased in the last spectrum (Figure 10D). A further comment on the structures of species I and II can be made from an analysis of the spectrum shown in Figure 10B.

In this spectrum the doublets D and E, which have been respectively assigned to the four  $\text{F}_1$  fluorine atoms of species I and the eight  $\text{F}_4$  fluorine atoms of species II, have practically identical intensities. If the proposed structures for species I and II are correct, we can expect the intensity of signal A, characteristic of fluorine atoms  $\text{F}_3$ , to be double that of signal B, characteristic of fluorine atoms  $\text{F}_6$ . Since the ratio of the intensity of these two signals A and B is effectively in this order, it is confirmed that species I is a bimolecular complex between  $\text{SbF}_5$  and  $\text{HSO}_3\text{F}$  and species II a trimolecular complex between 2 mol of  $\text{SbF}_5$  and 1 mol of  $\text{HSO}_3\text{F}$ .

#### b. Study of $\text{SbF}_5\text{-HSO}_3\text{F-CH}_3\text{CO}_2\text{H}$ Solutions.

We added to the solutions formed from 0.7 mol of  $\text{SbF}_5$  and 1 mol of  $\text{HSO}_3\text{F}$ , respectively, 0.6, 0.12, and 0.23 mol of acetic acid taking care ( $-78^\circ$ ) that only protonation took place. (The reaction is quantitative, see ref 10.) As is observed for water, the  $^{19}\text{F}$  nmr

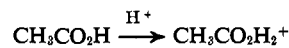

spectra of these solutions show the progressive decrease in the intensity of the signals of I and an increase in the intensity of the signals of II. Upon dehydration of protonated acetic acid to the methyloxocarbonium ion further changes in the solvent were noted. Figures

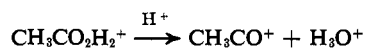

11A, B, and C are the  $^{19}\text{F}$  nmr spectra of the solutions formed from 0.7 mol of  $\text{SbF}_5\text{-HSO}_3\text{F}$  and 0.23 mol of  $\text{CH}_3\text{CO}_2\text{H}$  in which the acetic acid is ionized 32, 70, and 95% to acetyl cation, respectively. Figure 11D shows the pmr spectrum of a similar solution ionized to the extent of 95%. It was not possible, even after 30 min at  $30^\circ$ , to ionize completely the acetic acid in this medium. After ionization of the maximum quantity of acetic acid we observed in the  $^{19}\text{F}$  nmr spectrum, Figure 11C, the appearance of signal N which previously we attributed to the  $\text{SbF}_5\text{-OH}_2$  complex and in the same spectrum the absence of signal I characteristic of species IV. In the pmr spectrum of this solution (Figure 11D) the ratio  $h_{\text{water}}/h_{\text{acid}}$  is 0.91. For an analogous ratio in the  $\text{SbF}_5\text{-HSO}_3\text{F-H}_2\text{O}$  solutions, we have observed identical modifications in their  $^{19}\text{F}$  nmr spectra. The reaction explaining in this case the phenomenon can be written



B being the water liberated from the ionization of protonated acetic acid, or un-ionized acetic acid, both competing in the equilibrium. Probably these changes are not dependent on the nature of the base added to the system, but only on the quantity of protons that this



base is able to trap in this medium. The following observations confirm this hypothesis. Three solutions of  $\text{SbF}_5\text{-HSO}_3\text{F}$  mixed with acetic acid and methanol were prepared with the following concentrations: (1)  $\text{SbF}_5$  (0.7 mol) +  $\text{HSO}_3\text{F}$  (1 mol) +  $\text{CH}_3\text{CO}_2\text{H}$  (0.06 mol); (2)  $\text{SbF}_5$  (0.7 mol) +  $\text{HSO}_3\text{F}$  (1 mol) +  $\text{CH}_3\text{CO}_2\text{H}$  (0.12 mol); (3)  $\text{SbF}_5$  (0.7 mol) +  $\text{HSO}_3\text{F}$  (1 mol) +  $\text{CH}_3\text{OH}$  (0.12 mol). On warming the first solution to room temperature the acetic acid was completely ionized to the acetyl cation. The second solution was prepared at  $-78^\circ$  and acetic acid was only protonated as was methanol in the third solution. In the second and third solutions it is clear that 0.12 mol of proton acid is trapped. In the first solution as shown in the subsequent discussion 0.12 mol of acid proton is trapped.

The  $^{19}\text{F}$  nmr spectra of these solutions were also recorded and show perfectly analogous behavior confirming the previous hypothesis which in fact means that the structure of the  $\text{SbF}_5\text{-HSO}_3\text{F}$  system is a function of its acidity. It is of further interest to measure the acidity of these systems and to be able to elucidate for each compound the minimum acidity needed for its ionization. This study will be pursued in our work.

**c. Study of the Hydronium Ion,  $[\text{H}_3\text{O}]^+$ .** We prepared the following solutions: (1) and (2) as in previous section; (4)  $\text{SbF}_5$  (0.7 mol) +  $\text{HFSO}_3$  (1 mol) +  $\text{CH}_3\text{CO}_2\text{H}$  (0.16 mol); (5)  $\text{SbF}_5$  (0.7 mol) +  $\text{HFSO}_3$  (1 mol) +  $\text{CH}_3\text{CO}_2\text{H}$  (0.218 mol). By warming each of these solutions at room temperature the acetic acid was ionized completely. The pmr spectra consist of

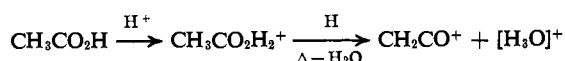

three peaks: one at  $\delta$  4.35 which is characteristic of the three equivalent protons of  $\text{CH}_3\text{CO}^+$ , another between  $\delta$  10.25 and 10.35 due to the cleaved water, and a third between  $\delta$  12.05 and 10.60 characteristic of the acid protons. If we consider that the cleaved water is in all cases trapped in the  $[\text{OH}_3]^+$  form, it is obvious that the acid system (proton reservoir) must furnish two protons per mole of acetic acid ionized; that is, 0.12, 0.24, 0.32, and 0.436 mol of protons, respectively, for the four solutions above. The "water" signal must be then the total 0.18, 0.36, 0.48, and 0.654 mol of protons and the acid signal must equal the number of moles of protons remaining in the reservoir, that is 0.88, 0.76, 0.68, and 0.564. The theoretical ratio  $h_{\text{water}}/h_{\text{acid}}$ , considering that all of the eliminated water is in the  $[\text{OH}_3]^+$  form, is summarized for the four preceding solutions in Table II together with the experimental

**Table II.** Theoretical and Experimental Ratios  $h_{\text{water}}/h_{\text{acid}}$

Solutions	$h_{\text{H}_2\text{O}}/h_{\text{acid}}$		$\Delta$
	Theoret	Exptl	
1	0.20	0.20	0.00
2	0.47	0.42	0.05
4	0.71	0.56	0.15
5	1.15	0.90	0.24

ratios found and the difference ( $\Delta$ ) between these two ratios. For a low concentration of acetic acid (solution 1), the difference is equal to zero. This indicates that under these conditions the cleaved water is in the  $[\text{OH}_3]^+$

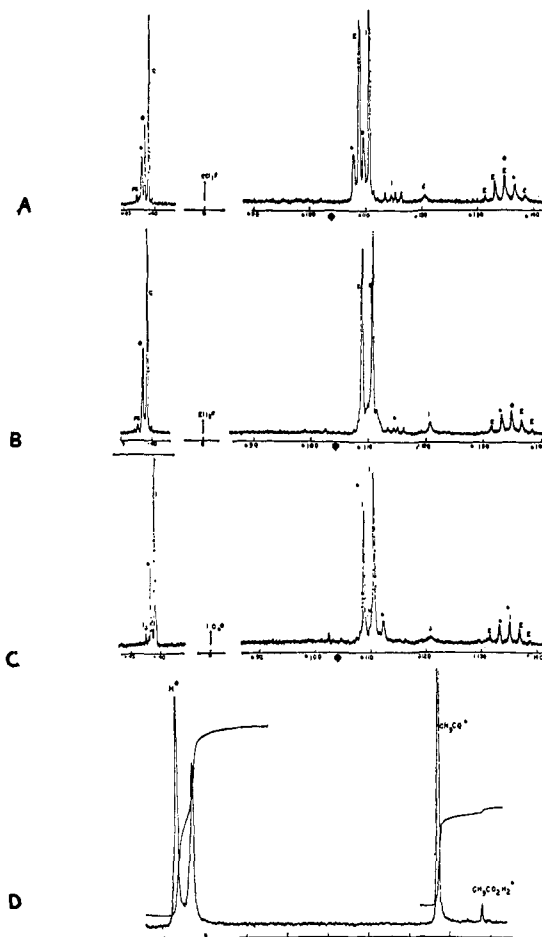

Figure 11. (A)  $^{19}\text{F}$  nmr spectrum of solution formed by  $\text{SbF}_5$  (0.7 mol),  $\text{HSO}_3\text{F}$  (1 mol), and  $\text{CH}_3\text{CO}_2\text{H}$  (0.23 mol) ionized to 32%, spectrum recorded at  $-50^\circ$ ; (B)  $^{19}\text{F}$  nmr spectrum of solution formed by  $\text{SbF}_5$  (0.7 mol),  $\text{HSO}_3\text{F}$  (1 mol), and  $\text{CH}_3\text{CO}_2\text{H}$  (0.23 mol) ionized to 70%, spectrum recorded at  $-50^\circ$ ; (C)  $^{19}\text{F}$  nmr spectrum of solution formed by  $\text{SbF}_5$  (0.7 mol),  $\text{HSO}_3\text{F}$  (1 mol), and  $\text{CH}_3\text{CO}_2\text{H}$  (0.23 mol) ionized to 95%, spectrum recorded at  $-20^\circ$ ; (D) pmr spectra of solution formed by  $\text{SbF}_5$  (0.7 mol),  $\text{HSO}_3\text{F}$  (1 mol), and  $\text{CH}_3\text{CO}_2\text{H}$  (0.23 mol) ionized to 95%, spectrum recorded at  $-20^\circ$ .

form. For solution 1 the areas of the signals of "water" and acetyl cation protons which constitute an internal standard are identical, confirming the indication that the cleaved water is trapped in the  $[\text{OH}_3]^+$  form. As the concentration of acetic acid is increased (solutions 2, 4, and 5) the experimental ratio becomes smaller than the theoretical ratio and the difference increases with the concentration of water formed from ionization. This shows that the acid reservoir does not supply, under these conditions, as many protons as there are water molecules cleaved and we must consequently consider that these protons are then distributed between two or more molecules of water. In the nmr spectra of solutions 2, 4, and 5 we also compared the area of the characteristic signal of acetyl cation to that of "water." These two areas remain practically identical in the case of solution 2. The difference is indeed very small and consequently almost all of the 0.12 mol of water is still in the  $[\text{H}_3\text{O}]^+$  form. But in the case of solutions 4 and 5, the area of the water signal becomes smaller than that of the acetyl cation confirming the fact that the water liberated from the ionization of protonated acetic

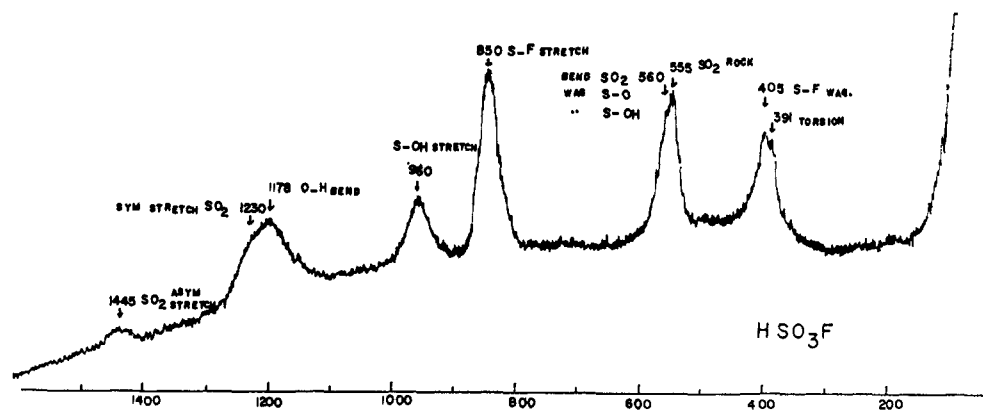
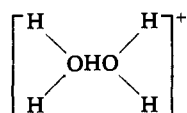
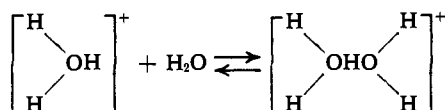

Figure 12. Raman spectrum of  $\text{HSO}_3\text{F}$ .

acid cannot be entirely trapped in the  $\text{H}_3\text{O}^+$  form due to a deficiency of protons in the proton reservoir. We have calculated this lack of protons from the previous experimental data. Let us consider the case of solution 5 in which the deficiency is at a maximum. (We note that the concentration in  $\text{CH}_3\text{CO}_2\text{H}$  of solution 5 is weaker than that presented in Figure 11C, and after complete ionization of the 0.218 mol of acetic acid, the characteristic N signal of the  $\text{SbF}_5\text{-OH}_2$  species does not appear.) If  $X$  is the area of the characteristic absorption of "water," and  $Y$  the absorption characteristic of the "acid" we can write:  $X + Y = 1.218$  mol of protons (total quantity of protons in the system) and  $X/Y = 0.90$  (experimental data) from which we get  $X = 0.577$  mol of protons and  $Y = 0.641$  mol of protons. With the initial quantity of acid protons equal to 1 mol, the acid reservoir can then give  $1 - 0.641 = 0.359$  mol of protons at the maximum. From this 0.359 mol, 0.218 mol was used with 0.218 mol of OH from acetic acid to form 0.218 mol of water, and the excess  $0.359 - 0.218 = 0.141$  mol protonates the 0.218 mol of water thus formed. Since it is not possible to ionize more than 0.218 mol acetic acid in the solution used [ $\text{SbF}_5$  (0.7 mol)– $\text{HSO}_3\text{F}$  (1 mol)] to trap 0.218 mol of water formed in the whole ionization and then stabilize 0.218 mol of acetyl cation it is necessary to use at least 0.141 mol of protons (*i.e.*, a little more than half of the water concentration). Consequently for the acetyl cation, one proton can—at most—trap two molecules of water. If then for low concentration of



acetic acid the cleaved water is found completely in the form  $[\text{OH}_3]^+$ , we must consider the equilibrium



We might by extrapolation consider the possibility of the existence of complexes less well defined between one proton and three or more molecules of water. However, it is clear that since we are at the limit of acetic acid ionization, these complexes are unstable with regard to acetyl cation and also with regard to

$\text{SbF}_5$  because in these conditions the  $\text{SbF}_5\text{-OH}_2$  complex is formed (signals N).

In conclusion, the maximum proton concentration that the system [ $\text{SbF}_5$  (0.7 mol)– $\text{HSO}_3\text{F}$  (1 mol)] can provide to ionize 0.218 mol of acetic acid is practically identical with the maximum concentration of anion II,  $[\text{Sb}_2\text{F}_{10}\text{SO}_3\text{F}]^-$ , which can be formed in this medium: 0.359 mol of  $\text{H}^+$  for  $0.7/2 = 0.350$  mol of  $[\text{Sb}_2\text{F}_{10}\text{SO}_3\text{F}]^-$ . Thus the only anion present in these systems is the anion II and after ionization of 0.218 mol of acetic acid in this system the equilibrium of charges is ensured by

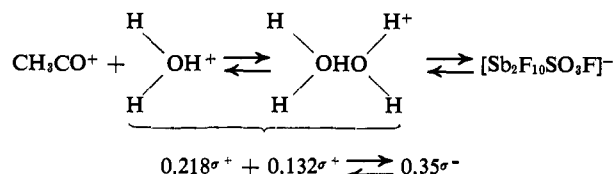

The 0.65 mol of uncomplexed fluorosulfuric acid must be considered as a relatively nonnucleophilic solvent for these cations at low temperature, even though at room temperature there is an exchange between  $\text{HSO}_3\text{F}$  and protonated water.

**D. Raman Spectroscopic Study of Systems Formed by  $\text{SbF}_5$ ,  $\text{HSO}_3\text{F}$ ,  $\text{SO}_2$ ,  $\text{HCl}$ , and  $\text{H}_2\text{O}$ .** a. **Raman Spectrum of Fluorosulfuric Acid.** The Raman spectrum of fluorosulfuric acid is shown in Figure 12 with an assignment of the fundamental vibrations in accordance with previous work by Gillespie and Robinson.<sup>12</sup>

In order to verify that the line at  $1178\text{ cm}^{-1}$  was effectively due to a vibration involving the hydrogen atom we prepared a sample of deuterated fluorosulfuric acid (88% D). In the Raman spectrum of this sample the essentially complete disappearance of the  $1178\text{ cm}^{-1}$  line was noted as was the formation of a new line at  $1085\text{ cm}^{-1}$  that we can assign to a vibrational movement involving the deuterium atom.

The ratio of these two frequencies,  $1178/1085 = 1.08$ , is obviously very different from the theoretical ratio (1.41); however, the O–H bond of such a strong acid is most certainly very perturbed. For example in acetylene the low value 1.12 for the ratio  $\nu_{\text{CH}}/\nu_{\text{CD}}$  is reportedly due to perturbation by the acetylenic group.<sup>13</sup>

b. **Raman Spectra and Structure of Antimony Pentafluoride.** Considering antimony as the central

(12) R. J. Gillespie and E. A. Robinson, *Can. J. Chem.*, **40**, 644 (1962).

(13) G. Herzberg, "Infrared and Raman Spectra of Polyatomic Molecules," D. Van Nostrand Co., Princeton, N. J., 1945.

atom bonded to five fluorine atoms, only those of the different possible arrangements<sup>13</sup> summarized in Table III are tenable. Previous work on the Raman spectra of pure antimony pentafluoride (summarized in Table IV) was interpreted<sup>14,15</sup> by considering the molecule as a trigonal bipyramid. From a <sup>19</sup>F nmr study<sup>16</sup> it was shown that antimony pentafluoride was probably polymerized with a square pyramid as the elementary

**Table III.** Symmetry of Molecules and Corresponding Raman Lines

	Symmetry	No. of Raman lines	No. of polarized lines
Plane pentagon	D <sub>5h</sub>	3	1
Trigonal bipyramid	D <sub>3h</sub>	6	2
Square pyramid	C <sub>2v</sub>	9	3

**Table IV.** Raman Spectral Lines of Antimony Pentafluoride

Gaunt <sup>14</sup>	Krishna <sup>15</sup>	Hyman <sup>17</sup>	This work
716 s	716 polarized	712 s	716 polarized
667 s	667 polarized	668 s	670 polarized
			489
			351
			302
264 m		265 m	266
228 m diffus.		228	231
			188
			149
50 vw		150 vw	140 polarized

structure. One fluorine atom on the square of each elementary structure is bonded with two different antimony atoms (*cis* association) so that antimony has an approximately octahedral coordination. We therefore undertook a reinvestigation of the Raman spectrum of antimony pentafluoride and noted (Figure 13) additional lines previously unobserved (188, 302, 351, 489 cm<sup>-1</sup>). The 150-cm<sup>-1</sup> line observed by Hyman, *et al.*,<sup>17</sup> is in fact a doublet (140–149 cm<sup>-1</sup>). The shape of this doublet recorded with polarization parallel (Figure 13B) and perpendicular (Figure 13C) shows that the 140-cm<sup>-1</sup> line is polarized. Therefore the total number of Raman lines is ten, three of which are polarized. If one of these extremely weak lines is interpreted as an overtone, the spectrum becomes consistent with that of a square pyramidal structure. This assignment, neglecting the fluorine-exchange reaction, required that the associated system be formed by an array of square pyramids bonded together by coordinative bonds of weak intensity instead of two covalent bonds of identical intensity as previously suggested. Thus only very weak perturbations are observed in the vibrational spectrum of the square pyramid. The molecular transition rates are extremely high (10<sup>-12</sup> sec) compared with the exchange reaction rates (2 × 10<sup>-3</sup> sec at -10°)<sup>18</sup> and therefore antimony

(14) J. Gaunt and J. B. Ainscough, *Spectrochim. Acta*, **10**, 57 (1957).

(15) H. G. Krishna Pillai, K. Ramaswamy, and A. Peramal, *Indian J. Pure Appl. Phys.*, **3**, 180 (1965).

(16) C. J. Hoffman, B. E. Holden, and W. L. Jolly, *J. Phys. Chem.*, **62**, 364 (1958).

(17) H. H. Hyman, L. A. Quarterman, M. Kilpatrick, and J. J. Katz, *ibid.*, **65**, 123 (1961).

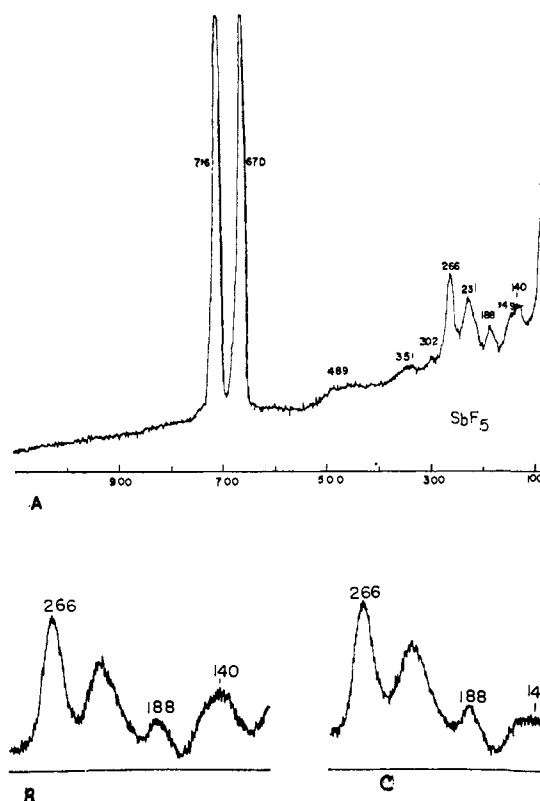

**Figure 13.** (A) Raman spectrum of SbF<sub>5</sub>; (B) Raman spectrum of SbF<sub>5</sub> polarized parallel; (C) Raman spectrum of SbF<sub>5</sub> polarized perpendicular.

pentafluoride may be present in the square pyramidal form at this time scale.

**c. Raman Spectra of SbF<sub>5</sub>-HSO<sub>3</sub>F Solutions.** The Raman spectra of mixtures prepared from 1 mol of HSO<sub>3</sub>F and 0.209, 0.5, 0.8, and 1 mol of SbF<sub>5</sub> were obtained (Figure 14). Comparing these spectra with those of the starting materials we noted first the disappearance of SbF<sub>5</sub> lines at 140, 149, and 188 cm<sup>-1</sup> and the formation of 212-, 238-, 275-, and 294-cm<sup>-1</sup> lines in the region 200–300 cm<sup>-1</sup>. We did not assign these lines nor those very broad ones at 400–405, 485, 550, and 595, and the shoulder at 437 cm<sup>-1</sup>. However, it seems by analogy that the vibrations at 652 and 690 cm<sup>-1</sup> correspond to the 670–716-cm<sup>-1</sup> symmetrical modes of pure SbF<sub>5</sub>.

The 850- and 960-cm<sup>-1</sup> lines characteristic of S-F and S-OH stretching modes in HSO<sub>3</sub>F are progressively replaced by two broad lines at 881 and 1012 cm<sup>-1</sup> which are certainly the vibrational frequencies of the same groups in complexes I (HSbF<sub>5</sub>SO<sub>3</sub>F) and II (HSb<sub>2</sub>F<sub>10</sub>SO<sub>3</sub>F).

The 1178-cm<sup>-1</sup> line assigned to the bending mode of O-H disappears very quickly in the spectra of these mixtures and the 1230- and 1445-cm<sup>-1</sup> lines of the symmetric and asymmetric stretch of SO<sub>2</sub> are not disturbed. The disappearance of this frequency at 1178 cm<sup>-1</sup> was also observed by Gillespie and Robinson<sup>12</sup> in the spectra of the HSO<sub>3</sub>F-AsF<sub>3</sub> system and was assigned to the change in the nature and extent of hydrogen bonding caused by diluting the HSO<sub>3</sub>F with AsF<sub>3</sub> which shifts the signal of this bond so that it is obscured by another line.

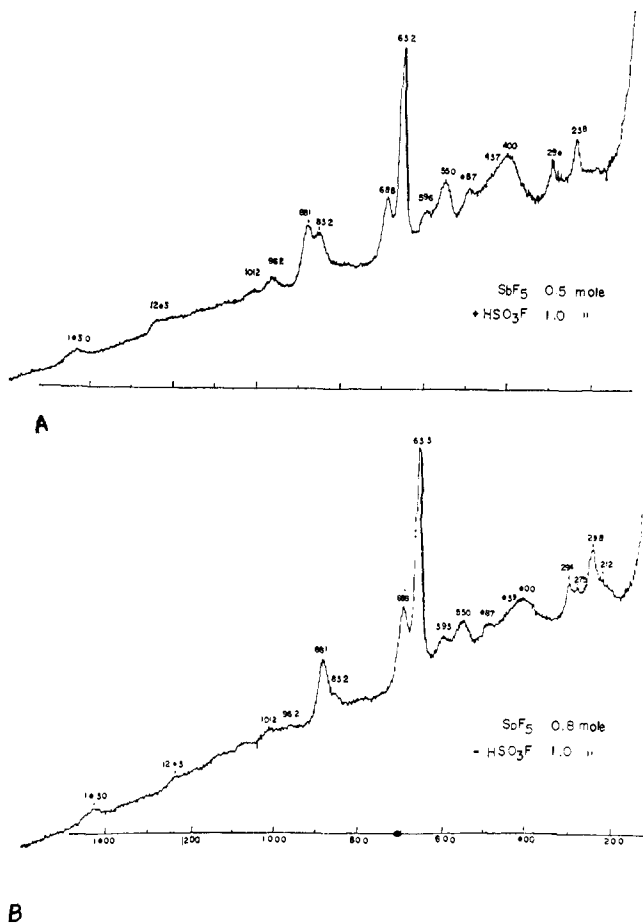

Figure 14. (A) Raman spectrum of  $\text{SbF}_5:\text{HSO}_3\text{F} = 0.5$  solution; (B) Raman spectrum of  $\text{SbF}_5:\text{HSO}_3\text{F} = 0.8$  solution.

#### d. Raman Spectra of $\text{SbF}_5\text{-HSO}_3\text{F-SO}_2$ Solutions.

Figure 15 is the Raman spectrum of the solution formed from 0.8 mol of  $\text{SbF}_5$ , 1 mol of  $\text{HSO}_3\text{F}$ , and 3.75 mol of  $\text{SO}_2$ . In addition to the previously discussed spectra of  $\text{SbF}_5\text{-HSO}_3\text{F}$  solutions the fundamental frequencies of  $\text{SO}_2$  appear at 525, 1144, and 1331  $\text{cm}^{-1}$ . A new line at 1106  $\text{cm}^{-1}$  which is assigned to the  $\nu_1$  vibration of  $\text{SO}_2$  associated with  $\text{SbF}_5$  in the complex  $\text{SbF}_5\text{-SO}_2$  and two lines at 944 and 830  $\text{cm}^{-1}$  which are probably the  $\text{HSO}_3\text{F}$  lines shifted by a solvent effect are also noted. We have seen previously that formation of the  $\text{SbF}_5\text{-SO}_2$  complex regenerates an important quantity of fluorosulfuric acid. The other parts of this spectrum do not undergo any change except the broad line at 595  $\text{cm}^{-1}$  which becomes a sharper line at 605  $\text{cm}^{-1}$  while the O-H signal at 1178  $\text{cm}^{-1}$  is absent.

**e. Raman Spectra of  $\text{SbF}_5\text{-HSO}_3\text{F-SO}_2\text{-H}_2\text{O}$  Solutions.** As discussed previously, it was of interest to know the Raman spectrum of complex II because its concentration in solutions containing organic cations remained significant. To an  $\text{SbF}_5:\text{HSO}_3\text{F} = 0.8$  solution, we added water until the ratio  $h_{\text{water}}/h_{\text{acid}}$  in its pmr spectra was 0.53. In this case the concentrations of complexes I and II are in the ratio 2:1. The Raman spectrum of the solution, recorded with and without  $\text{SO}_2$  as a solvent, was shown to be practically identical with that of the same solution before water was added. The only variation to be found was a slight difference in the intensity of the two lines 830 and 883  $\text{cm}^{-1}$  in favor of the 830- $\text{cm}^{-1}$  line. These two lines remained, in all

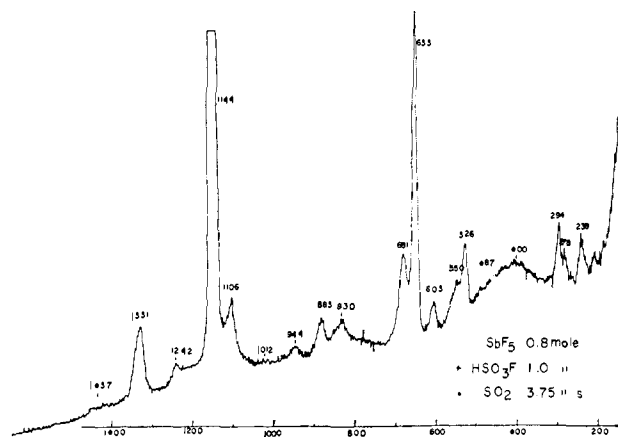

Figure 15. Raman spectrum of the solution formed by  $\text{SbF}_5$  (0.8 mol),  $\text{HSO}_3\text{F}$  (1.0 mol), and  $\text{SO}_2$  (3.75 mol).

cases, very broad. The Raman spectrum of complex II seems to have no additional lines with respect to complex I.

**f. Raman Spectra of  $\text{SbF}_5\text{-HSO}_3\text{F-SO}_2\text{-HCl}$  Solutions.** To an  $\text{SbF}_5\text{-HSO}_3\text{F} = 0.8 + \text{SO}_2$  solution, we added increasing quantities of HCl. The spectrum shown in Figure 16 is that of the system formed from 0.70 mol of HCl + 0.80 mol of  $\text{SbF}_5$  + 1.0 mol of  $\text{HSO}_3\text{F}$  + 4.5 mol of  $\text{SO}_2$ . Upon comparison with those spectra obtained without HCl we noted the progressive disappearance of the 1012- and 883- $\text{cm}^{-1}$  lines assigned to S-O and S-F stretching modes of complexes I and II, similar to that observed for the 1106- $\text{cm}^{-1}$  line characterizing the  $\text{SbF}_5\text{-SO}_2$  complex. At the same time the 830- and 842- $\text{cm}^{-1}$  lines assigned to S-F and S-OH stretching modes of  $\text{HSO}_3\text{F}$  regain a significant intensity. In the region 300-600  $\text{cm}^{-1}$ , the 600- $\text{cm}^{-1}$  line is practically not perturbed. We noted a decrease of the 550- $\text{cm}^{-1}$  line, and the 487- $\text{cm}^{-1}$  line appeared clearly again. The 437- $\text{cm}^{-1}$  line, which we had always observed as a shoulder, became very clear but the most important modification was the formation of the very strong line at 387  $\text{cm}^{-1}$ . If we also consider the lower energy frequencies not observable in the spectrum presented in Figure 16, those at 254-278  $\text{cm}^{-1}$  are not perturbed but the intensity of the 238- $\text{cm}^{-1}$  line decreases progressively until it reaches zero at which point  $\text{SbF}_5$  and HCl are in equimolar concentration. These observations confirm the nmr results which showed that HF or HCl reacts with complexes I and II to form species III ( $\text{HSbF}_6$ ) and IV ( $\text{HSb}_2\text{F}_{11}$ ) and regenerates fluorosulfuric acid. Species IV is therefore probably responsible for the low-intensity Raman lines at 437 and 387  $\text{cm}^{-1}$ . The  $\text{SbF}_6^-$  ion studied<sup>18</sup> in  $\text{LiSbF}_6$  in the solid form has three Raman lines at 294, 558, and 668  $\text{cm}^{-1}$  which are visible in our spectra at 294 and 550  $\text{cm}^{-1}$  and one doublet band at 653-681  $\text{cm}^{-1}$ .

## Conclusions

The structure of the  $\text{SbF}_5\text{-HSO}_3\text{F}$  solutions can be represented by equilibria 1-6 which are in agreement with all experimental observations.

(18) G. M. Begun and A. C. Rutenberg, *Inorg. Chem.*, **6**, 2212 (1967).



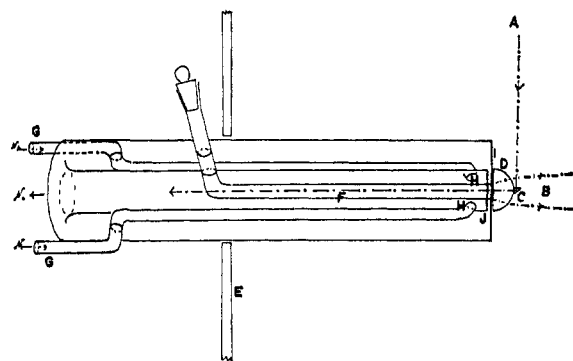

Figure 17. Low-temperature Raman cell.

oleum system. In these media the acetyl cation (for example) can be formed from acetic anhydride or acetic acid but only in a sufficiently concentrated oleum where the negative charge can be well dispersed in the  $\text{HS}_2\text{O}_7^-$  anion.<sup>20</sup> A sulfuric acid solution in acetic anhydride contains a covalent species, the mixed anhydride  $\text{CH}_3\text{COOSO}_3\text{H}$ , which can only give rise to sulfonation of aromatic compounds; the aromatic acetylating species in this medium is the mixed anhydride  $\text{HO}_2\text{CCH}_2\text{SO}_3\text{COCH}_3$ .<sup>21</sup>

### Experimental Section

**Nmr Spectra.** Nmr proton and  $^{19}\text{F}$  spectra were obtained on a Varian Associates Model A56/60A spectrometer. Spin-spin decoupling experiments for  $^{19}\text{F}$  have been done on a Varian Associates

(20) G. E. Maciel and D. D. Traficante, *J. Phys. Chem.*, **70**, 1314 (1966).

(21) A. A. Commeyras, Thèse de doctorat, University of Montpellier, Montpellier, France, 1965.

Model HA 60 spectrometer. External (capillary) TMS and  $\text{CCl}_3\text{F}$  were used as references.

**Raman Spectra.** Raman spectra were obtained on a Cary 81 Raman spectrophotometer with laser source (50 mW gas laser using the 6328 Å HeNe line). At room temperature a 26- $\mu\text{l}$  capillary liquid sample cell for coaxial viewing was used (Cary No. 8173515). At low or high temperatures, a special Raman cell adapted to the coaxial viewing Cary system was built (all Pyrex or quartz, volume 9 ml). Figure 17 shows this cell in a working position: A is the laser beam (incident light); B is the scattered beam; C and D are parts of the Cary instrument directing the laser beam (A) into the sample (F), and the scattered beam (B) into the spectrophotometer. The wall of the microcell compartment is E. Nitrogen controlled at the temperature desired by a Varian temperature controller goes into H, through a vacuum-jacketed thermostat to the sample. We used this cell between  $-100$  and  $+100^\circ$  without any trouble. Within these limits, the difference in temperatures between the top and bottom of the cell is  $10^\circ$ . The vacuum jacket was sealed at  $10^{-6}$  mm, therefore even at  $-100^\circ$  after 2 hr there was no condensation over plane I. The space between planes I and J is 1 mm.

**Materials.** Commercial antimony pentafluoride was purified by double distillation at atmospheric pressure in an all-glass apparatus. In a third distillation a constant-boiling fraction (bp  $142\text{--}143^\circ$ ) was collected directly into a Teflon bottle. Fluorosulfuric acid was purified by double distillation at atmospheric pressure in an all-glass apparatus.

The mixtures of  $\text{SbF}_5\text{--HSO}_3\text{F}$  with  $\text{SO}_2$ ,  $\text{RX}$ ,  $\text{RCOX}$ ,  $\text{HX}$ ,  $\text{ROH}$ ,  $\text{RCO}_2\text{H}$ , and  $\text{HOH}$  were prepared at low temperature (generally Dry Ice-acetone) as described previously. Each constituent was weighed with a minimum accuracy of  $\pm 0.2$  g.

Deuterated fluorosulfuric acid was prepared by exchange between  $\text{HSO}_3\text{F}$  and 99.9%  $\text{D}_2\text{SO}_4$ . After three consecutive distillations of an equimolar mixture, we obtained in 90% yield fluorosulfuric acid with  $>95\%$  deuterium content.

**Acknowledgment.** Partial support of the work by grants of the National Science Foundation and the Petroleum Research Fund administered by the American Chemical Society is gratefully acknowledged. The award of a postdoctoral fellowship to Dr. Auguste Commeyras by NATO is also acknowledged.